

Microcalorimetric study on the growth and metabolism of *Pseudomonas aeruginosa*

N. Lago · J. L. Legido · M. I. Paz Andrade ·
I. Arias · L. M. Casás

ESTAC2010 Conference Special Issue
© Akadémiai Kiadó, Budapest, Hungary 2010

Abstract Microcalorimetry is an experimental technique which allows us to precisely measure the energy released as a consequence of any transformation process. All organisms produce heat as a consequence of metabolism. The rate of heat production is an adequate measurement of metabolic activity of organisms and their constituent parts, cells and sub-cellular levels. Microorganisms produce small amounts of heat, in the order of 1–3 pW per cell. Despite the low quantity of heat produced by bacteria, their exponential replication in culture medium allows their detection using microcalorimetry. This study is a microcalorimetric study of the growth and metabolism of the bacterium *Pseudomonas aeruginosa*, using the heat liberated as a consequence of bacterial metabolism. With this aim, we used a Calvet microcalorimeter, inside which two Teflon screw-capped stainless steel cells were located (sample and reference). Experiments were carried out at final concentrations of 10^6 , 10^5 , 10^3 and 10 CFU/mL, and a constant temperature of 309.65 K was maintained within the microcalorimeter. Recording the difference in calorific potential over time we obtained *P. aeruginosa*'s growth curves. The shape of these curves is characteristic and has a

single phase. Thus, the heat flow curves were mathematically studied to calculate the growth constant and generation time of this bacterium.

Keywords Microcalorimetry · *Pseudomonas aeruginosa* · Bacteria · Metabolism

Introduction

Metabolism can be described as the set of chemical reactions that take place within the cell and involve energy flow and participation of certain enzymes. It consists of two fundamental processes: (a) *Catabolism*, in which large molecules are broken down into smaller simpler ones with the release of energy during the process. A part of this energy is stored and available for producing work whilst the rest is lost as heat. (b) *Anabolism*, wherein complex molecules are produced from simple ones with consumption of such stored energy. These are, therefore, a set of chemical reactions that are accompanied by a change of energy [1].

Growth is an essential response to the physico-chemical environment by microorganisms and involves their replication and change in cell size. Microorganisms can grow under a variety of physical, chemical and nutritional conditions. They extract nutrients from a nutrient medium and convert them into biological compounds. A part of such nutrients is used for biosynthesis and generation of products.

Growth curves show different perfectly defined phases, namely: latent, logarithmic, stationary and cell death. Microorganisms grow and divide up to a maximum during the *logarithmic stage* according to their genetic potential and media culture conditions. Characteristic parameters for

N. Lago · I. Arias
Servicio de Farmacia, Complejo Hospitalario Universitario de
Vigo (Xeral-Ciés), c/Pizarro no 22, 36202 Vigo, Spain

J. L. Legido · L. M. Casás (✉)
Departamento de Física Aplicada, Facultade de Ciencias
Experimentais, Universidade de Vigo, Lagoas Marcosende s/n,
36310 Vigo, Spain
e-mail: lmcasas@uvigo.es

M. I. Paz Andrade
Departamento de Física Aplicada, Facultade de Física,
Universidade de Santiago de Compostela, 15706 Santiago de
Compostela, Spain

each bacterial strain can be obtained during this period from culture behaviour.

If n_0 is the number of cells at time 0 and n_t is the number of cells at time t , during the logarithmic phase of the growth curve, then we obtain the expression [2]:

$$n_t = n_0 \cdot e^{k \cdot t} \quad (1)$$

where k is the growth constant.

If we consider P_w as energy released by each cell, then it leads to the following equation:

$$n_t \cdot P_w = n_0 \cdot P_w \cdot e^{k \cdot t} \quad (2)$$

If we take into account that energy released at t zero is P_0 and P_t is the energy released at time t , then we get:

$$P_t = P_0 \cdot e^{k \cdot t} \quad (3)$$

$$\ln P_t = \ln P_0 + k \cdot t \quad (4)$$

Thus, the growth constant can be obtained by selecting two points from the exponential phase of a bacterial growth curve.

Generation time G is defined as the time taken by a population to duplicate its number and is expressed as:

$$G = \frac{(\ln 2)}{k} \quad (5)$$

Microcalorimetry arouses interest in biological sciences because heat flow is closely related to kinetics and thermodynamics of biological processes. Therefore, heat variations produced as a consequence of chemical reactions which take place during metabolism can be used to monitor bacterial growth and observe the influence of external agents [2, 3].

All living beings produce heat as a consequence of their metabolism. Heat rate is a good measure of metabolic activity in organisms and their constituents and at their cellular and sub-cellular levels [4]. Heat generated by just one cell lies within a range 1–80 pW. Human connective tissue cells (fibroblasts, lipocytes, etc.) have shown metabolic rates of about 25–80 pW/cell. On the other hand, microorganisms produce small amounts of heat in the magnitude of 1–3 pW/cell. Despite the low bacterial heat, their exponential replication in culture media permits their detection by microcalorimetry in a few hours time, even when samples have a low concentration, e.g.: 10 CFU/mL.

Microcalorimetry has been used in biology, pharmacology, biotechnology and ecology because of its high sensitivity, precision and simplicity; but its use in clinical practice has been quite limited so far.

The technique has been used for studying microbial cell growth and metabolism under different conditions [2, 5]. One of the most studied bacterial species, namely: *Staphylococcus aureus*, shows two strains: methicillin-resistant *S. aureus* and methicillin-sensible *S. aureus* [6], which can

be differentiated in a few hours, and thus can be of great relevance to clinical practice.

Calorimetry is especially valuable in microbiological research since it permits quick assessment of changes in metabolism, growth speed and efficacy in the presence of different agents [7–13]. Another advantage is that it can be followed in real time.

Despite the recent references cited, bacterial growth evolution through microcalorimetry is still quite unknown, and very few species have actually been studied. The sensitivity of the technique and availability of quick results mean that microcalorimetry is a technique that offers great potential for clinical development.

This article analyses the growth of *Pseudomonas aeruginosa* (ATCC 27853) by studying heat liberated during bacterial metabolism. To date, to our knowledge there are no studies on characterisation of the growth of this bacterium using a calorimetric method. Thus, in this study, a Calvet microcalorimeter was used and several experiments were carried out with concentrations ranging from 10 to 10^6 CFU/mL. The resultant growth curves were mathematically studied to calculate the growth constant and generation time of the said bacteria.

Materials and methods

Samples were prepared by adjusting turbidity concentration to 0.5 on the McFarland scale using a Densichek® optical densitometer. This concentration was used to make further dilutions using saline solution to obtain final concentrations of 10^6 , 10^5 , 10^3 and 10 CFU/mL.

The liquid culture medium used was digested Soya Casein.

The measures were carried out using a Calvet microcalorimeter [14] equipped with a device allowing operation in the absence of vapour phase, and having a calorimeter-cell volume of approximately 10 cm³. A Philips PM2535 multimeter and a data acquisition system were linked to the microcalorimeter. Calibration was performed electrically using a Setaram EJP30 stabilised current source. The precision in calorimetric signal was $\pm 1 \mu\text{V}$. Further details about the experimental method of operation have been published [15].

The external environment of the calorimeter was maintained at a constant temperature of 309.65 K. The reference cell was injected with 7 mL of culture medium + 1 mL of saline whilst the experimental cell was injected with just 7 mL of culture medium (Fig. 1). Both cells were then introduced through two cylindrical holes aligned in parallel, which extended from the upper part of the microcalorimeter to the internal thermopile chamber. The large distance that separates the cells from the entrance

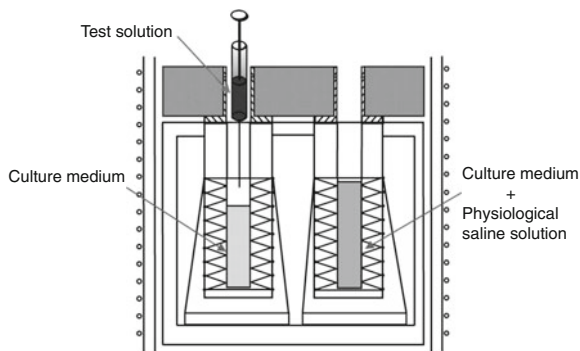

Fig. 1 Schematic diagram of the Calvet microcalorimeter internal block

permits minimisation of heat flow to the exterior. The system is allowed to stabilise for about 2 h, after which 1 mL of the established concentration is introduced into the experimental cell [16]. The experiment was also carried out with a sample not containing any bacteria (control).

Data were collected for more than 60 h, using the earlier mentioned data recovery and processing system.

Bacterial metabolism produces residues that modify the pH of the medium. Samples were subject to pH control using a basic 20+ pH-meter both before and after each experiment.

Results

A plot of calorific potential difference versus time gives us a graph for the *P. aeruginosa* growth curve at different concentrations (Fig. 2).

The shape of the heat flow curve of this Gram negative and strictly aerobic bacterium is characterised by the presence of just one phase, where the ascending part shows four discrete leaps and the descending one presents an exponential shape that is prolonged over time. These curves have a characteristic shape as shown in Table 1.

Time taken for signal detection decreases as culture concentration is increased. Bacterial growth in sample was observed even for low concentrations (10 CFU/mL) within a 5-h period.

Maximum peaks appear following a relative concentration order and even though more intense peaks are obtained at higher concentrations, no proportional relationship can be established. Moreover, all experiments showed a maximum growth peak prior to 13 h.

A mathematical analysis of the growth curves was carried out wherein an exponential component was observed in the *logarithmic stage* of each of the peaks, and can be represented by the following equation:

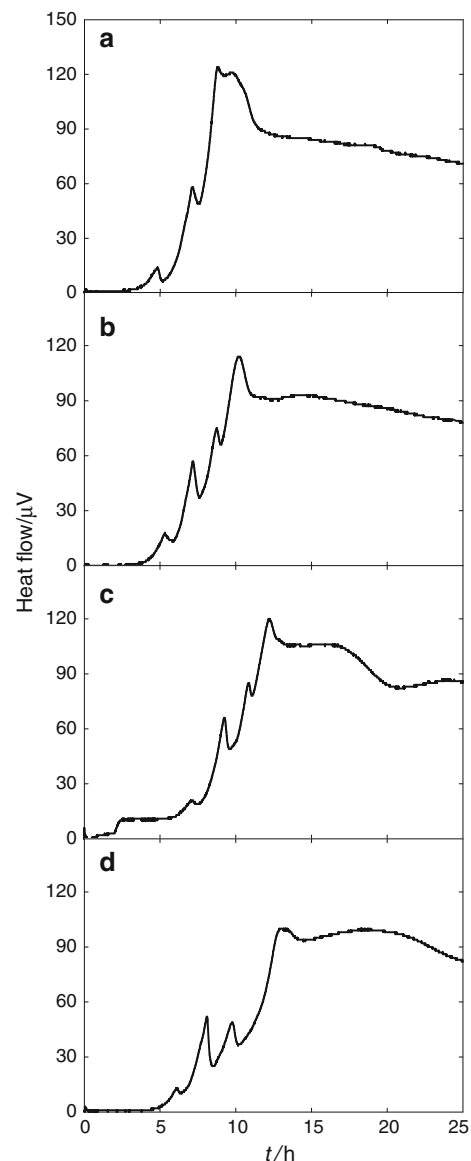

Fig. 2 Calorimetric signal versus time for the *P. aeruginosa* at the different studied concentrations: **a** 10^6 ; **b** 10^5 ; **c** 10^3 ; and **d** 10 CFU/mL

$$y = a \cdot e^{k \cdot t} \quad (6)$$

$$\ln y = \ln a + k \cdot t \quad (7)$$

Therefore, using this equation and by analogy with Eq. 4, we can calculate the value of the growth constant k , and obtain generation time G , from Eq. 5, for each of the *P. aeruginosa* growth curve phases (Table 2). Methods generally used to achieve such parameters are quite complex, tedious and require a lot of time.

pH measurements confirm acidification of the medium due to the accumulation of metabolic residues, and all samples showed a reduction of pH (Table 3). However, metabolic activity was not found to be inhibited by such acidification.

Table 1 Acquisition time and signal values and detection time for the first, second, third and fourth peaks in the growth curves of *P. aeruginosa* at the different studied concentrations

Concentration/CFU/mL	Detec. t/h	1st Peak		2nd Peak		3rd Peak		4th Peak	
		t/h	Signal/ μ V	t/h	Signal/ μ V	t/h	Signal/ μ V	t/h	Signal/ μ V
10^6	2.86	4.82	14	7.13	58	8.80	124	9.69	121
10^5	3.50	5.31	18	7.25	57	8.74	75	10.21	114
10^3	3.83	7.12	21	9.26	66	10.85	85	12.22	120
10	4.27	6.09	14	8.09	52	9.75	49	13.01	100

Table 2 Growth constant (k' , k'' , k''' , k) and generation time (G' , G'' , G''' , G) from Eq. 5, for each thermogram of the *P. aeruginosa*

Concentration/CFU/mL	k'/h^{-1}	G'/h	R^2	k''/h^{-1}	G''/h	R^2	k'''/h^{-1}	G'''/h	R^2	k/h^{-1}	G/h	R^2
10^6	1.409	0.492	0.943	1.319	0.526	0.994	0.921	0.753	0.999	^a		
10^5	1.679	0.413	0.964	1.252	0.554	0.986	0.817	0.849	0.993	0.595	1.164	0.996
10^3	0.966	0.717	0.857	0.887	0.782	0.997	0.665	1.042	0.990	0.441	1.570	0.995
10	1.434	0.483	0.933	1.029	0.674	0.988	0.640	1.083	0.977	0.404	1.714	0.992

^a Due to a high intensity of signal, the logarithmic phase cannot be clearly observed

Table 3 pH values before and after each experiment

Concentration/CFU/mL	Initial pH	T/K	Final pH	T/K
10^6	7.09	299.25	6.96	301.05
10^5	7.12	296.35	6.86	299.35
10^3	7.08	297.95	6.87	296.85
10	7.12	299.65	6.93	299.55
Control	7.06	301.65	7.29	301.95

Conclusions

Microcalorimetry facilitates metabolism and growth studies of *P. aeruginosa* through measurement of heat generated by metabolism. It facilitates identification of metabolic activity in cultures in a few hours time and, therefore, is of great interest for clinical practice since an early diagnosis permits quick treatment and, therefore, greater success.

When compared to other methods which are complex and slow, the calorimetric method furthermore allows us to quickly and accurately measure certain parameters such as the value of the growth constant and generation time, which are characteristic for each bacteria.

Acknowledgements We thank María Perfecta Salgado González and Sofia Baz Rodríguez for their collaboration with the technical measures, and the “Agrupación Estratégica de Biomedicina (INBIOMED)” financed by “Xunta de Galicia” for its support.

References

1. Prescott LM, Harley JP, Klein DA. Microbiology. 5th ed. New York: McGraw Hill; 2004.
2. Ma J, Qi WT, Yang LN, Yu WT, Xie YB, Wang W, Ma XJ, Xu F, Sun LX. Microcalorimetric study on the growth and metabolism of microencapsulated microbial cell culture. J Microbiol Methods. 2007;68:172–7.
3. James AM. Calorimetry. Past, present and future. In: Thermal and energetic studies of cellular biological systems. Bristol: IOP Publishing Ltd; 1987.
4. Trampuz A, Salzmann S, Antheaume J, Daniela AU. Microcalorimetry: a novel method for detection of microbial contamination in platelet products. Transfusion. 2007;47:1643–50.
5. Thomas M, Wolfgang B. Thermokinetic description of anaerobic growth of *Halomonas halodenitrificans* using a static microcalorimetric ampoule technique. J Biotechnol. 2003;101:267–74.
6. Baldoni D, Hermann H, Frei R, Trampuz A, Steinhuber A. Performance of microcalorimetry for early detection of methicillin resistance in clinical isolates of *Staphylococcus aureus*. J Clin Microbiol. 2009;47:774–6.
7. Hou AX, Xue Z, Liu Y, Qu SS, Wong WK. Antibacterial effects of monophyrinato ytterbium (III) complex and its free components on *Staphylococcus aureus* as determined by stop-flow microcalorimetry. Chem Biodivers. 2007;4:1492–500.
8. Xu XJ, Xue Z, Xiao Q, Hou AX, Liu Y. Antibacterial activities of novel diselenide-bridged bis(porphyrin)s on *Staphylococcus aureus* investigated by microcalorimetry. Biol Trace Elem Res. 2008;125:185–92.
9. Xu XJ, Chen CQ, Wang ZY, Zhang Y, Hou AX, Li CH, Liu Y. Study of antibacterial activity of ZnZnbisporphyrin complexes and its free components on *Staphylococcus aureus* by microcalorimetry. Biol Trace Elem Res. 2009;127:269–77.
10. Yan D, Han YM, Wei L, Xiao XH. Effect of berberine alkaloids on *Bifidobacterium adolescentis* growth by microcalorimetry. J Therm Anal Calorim. 2009;95:495–9.

11. Yang LN, Xian Sun L, Xu F, Zhang J, Zhao JN, Zhao ZB, Song CG, Wu RH, Ozao R. Inhibitory study of two cephalosporins on *E. coli* by microcalorimetry. *J Therm Anal Calorim.* 2010;100: 589–92.
12. Kong W, Li Z, Xiao X, Zhao Y, Zhang P. Activity of berberine on *Shigella dysenteriae* investigated by microcalorimetry and multivariate analysis. *J Therm Anal Calorim.* 2010;102:331–6.
13. Wang J, Cheng D, Zeng N, Xia H, Fu Y, Yan D, Zhao Y, Xiao X. Application of microcalorimetry and principal component analysis. Antibacterial evaluation of Benzoinum and Styrax on *Staphylococcus aureus* growth. *J Therm Anal Calorim.* 2010;102: 137–42.
14. Calvet E, Prat H. Microcalorimétrie: applications physico-chimiques et biologiques. Paris: Masson el Cie Editeurs; 1956.
15. Paz Andrade MI. Les développements récents de la microcalorimétrie et de la thermogenese. 1st ed. Paris: CRNS; 1967.
16. Lago Rivero N, Legido Soto JL, Arias Santos I, García Fortes F. Aplicaciones de la microcalorimetría como método de identificación precoz del crecimiento bacteriano. *Investig Cult Cienc Tecnol.* 2010;2:6–9.